

ARS 110

SOIL COMPACTOR
EU Stage IV / U.S. EPA Tier 4 Final

EXCELLING WHEREVER IT GOES

The compact design of Ammann ARS Soil Compactors improves manoeuvrability and flexibility, making the machines exceptionally productive. Safety is maximised through a new cab design that provides operators with 360° visibility and an intuitive, conveniently located control display. The proprietary ACE^{force} Intelligent Compaction system, which offers absolute compaction measurement and optional documentation, improves efficiency and quality. The availability of a wider range of centrifugal forces make the machine a perfect fit for many applications and varied materials.

PRODUCTIVITY

- High compaction output - faster compaction of thicker layers in fewer passes
- No-rear-axle concept – optimal stability and low center of gravity, which significantly improves safety on jobsites
- Variable range of vibration frequencies for added versatility
- ACE^{force} Intelligent Compaction tool for higher compaction efficiency

ERGONOMICS

- Spacious, quiet cab with integrated ROPS structure
- New multifunctional display for intuitive machine control and operation
- Excellent machine visibility with 360° view to machine edges and surroundings
- Innovative travel lever with speed adjustment and wider machine speed range (newly 5+1 speed instead of 3+1)

APPLICATIONS

- Medium and large compaction sites
- Transport construction
- Municipal and town roads
- Airport runways
- Rock fill dams
- Industrial zones
- Harbours
- City centers
- Dumpsite construction

SERVICEABILITY

- All service points and engine compartment accessible from the ground
- Wide-opening rear hood for easy and fast daily maintenance
- Tilttable cab for exceptional access to main hydraulic components, which significantly reduces labour
- ECOdrop – machine efficiency and reductions in fuel consumption and required fluids

MAXIMUM RECOMMENDED COMPACTED LIFT THICKNESS AT OPTIMAL WORKING CONDITIONS

	Rockfill	Sand / Gravel	Mixed Soils	Silt	Clay
ARS 110	* 1000 mm (39 in)	* 700 mm (28 in)	* 600 mm (24 in)	450 mm (18 in)	270 mm (11 in)
ARS 110 (PD)	-	-	* 600 mm (24 in)	* 450 mm (18 in)	* 320 mm (13 in)

* Recommended drum type

AMMANN

TECHNICAL SPECIFICATIONS
ARS 110 SOIL COMPACTOR
EU Stage IV / U.S. EPA Tier 4 Final

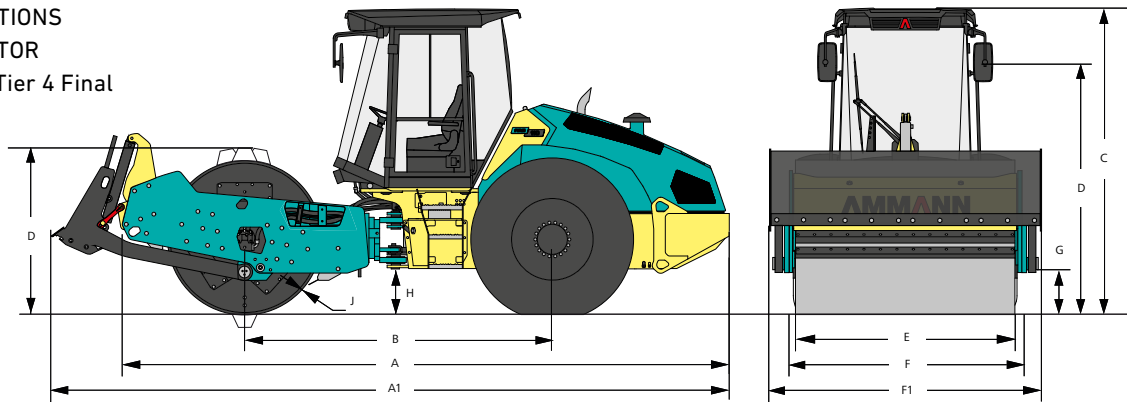

DIMENSIONS

A	MACHINE LENGTH	5900 mm (232.3 in)
A1	MACHINE LENGTH (BLADE)	6610 mm (260 in)
B	WHEELBASE	2990 mm (117.7 in)
C	MACHINE HEIGHT	2970 mm (116.9 in)
D	MACHINE HEIGHT (OPERATOR SEAT)	2200 mm (86.6 in)
E	DRUM WIDTH	2130 mm (83.9 in)
F	MACHINE WIDTH	2260 mm (89 in)
F1	MACHINE WIDTH (BLADE)	2440 mm (96 in)
G	CURB CLEARANCE	400 mm (15.7 in)
H	GROUND CLEARANCE	430 mm (16.9 in)
I	DRUM DIAMETER	1500 mm (59.1 in) /*1694 mm (66.7 in)
J	DRUM THICKNESS	25 mm (1 in) /*20 mm (0.8 in)

*PD

ENGINE

MANUFACTURER	Deutz TCD 3.6L4
POWER ACCORDING TO ISO 14396	100 kW (134 HP)
EXHAUST GAS AFTER-TREATMENT	EGR+DOC+SCR

EU Stage IV / U.S. EPA Tier 4 Final

COMPACTION FORCES

		PD
FREQUENCY I	25–31 Hz (1500–1860 vpm)	25–31 Hz (1500–1860 vpm)
FREQUENCY II	25–35 Hz (1500–2100 vpm)	25–35 Hz (1500–2100 vpm)
AMPLITUDE I	1.95 mm (0.077 in)	1.7 mm (0.067 in)
AMPLITUDE II	0.83 mm (0.033 in)	0.72 mm (0.028 in)
CENTRIFUGAL FORCE I	186–285 kN (41,814–64,071 lbf)	186–285 kN (41,814–64,071 lbf)
CENTRIFUGAL FORCE II	79–155 kN (17,759–34,845 lbf)	79–155 kN (17,759–34,845 lbf)

MISCELLANEOUS

BRAKES OPERATING	Hydrostatic
BRAKES PARKING	Multiple-disc spring brake
BRAKES EMERGENCY	Multiple-disc spring brake
FUEL TANK CAPACITY	345 l (91.1 gal)
ARTICULATION ANGLE	±36°
OSCILLATION ANGLE	±10°

WEIGHT & OPERATING CHARACTERISTICS

	HX	PD	HXP
OPERATING WEIGHT	10 860 kg (23,940 lb)	10 950 kg (24,140 lb)	11 485 kg (25,320 lb)
MAXIMUM WEIGHT	13 430 kg (29,610 lb)	13 520 kg (29,810 lb)	12 540 kg (27,650 lb)
STATIC LINEAR LOAD	30.3 kg/cm (169.6 lb/in)	30.6 kg/cm (171.4 lb/in)	–
PAD CONTACT SURFACE	–	–	120 cm ² (18.6 sq in)
PAD HEIGHT	–	–	100 mm (3.9 in)
MAX. TRANSPORT SPEED	12 km/h (7.5 MPH)	10 km/h (6.2 MPH)	12 km/h (7.5 MPH)
MAX. WORKING SPEED	7.6 km/h (4.7 MPH)	5.1 km/h (3.2 MPH)	7.6 km/h (4.7 MPH)
CLIMBING ABILITY WITHOUT / WITH VIBRATION	52% / 50%	67% / 55%	54% / 50%
TURNING RADIUS (INNER)	3625 mm (142.7 in)	3625 mm (142.7 in)	3625 mm (142.7 in)

STANDARD EQUIPMENT

- CE conformity
- Cab with ROPS structure
- Smooth drum with steel scrapers
- Multiple frequencies / 2 amplitudes vibration system
- External draining points
- Working headlights (front and rear)
- Inter wheel flow divider
- Ergonomic and suspended operator seat
- Multifunctional operator display
- Telematics ready

OPTIONAL EQUIPMENT

- Air-conditioning (cab version only)
- Drum - PD version / steel scrapers
- Drum - PD shell kit / steel scrapers
- Smooth drum - vulcalon scrapers
- ACE^{force} - Ammann Compaction Expert
- HX drive
- ATC (Ammann Traction Control)
- Warning beacon
- Backup alarm
- Dozer blade